

ILLUSTRATED PARTS BREAKDOWN

PARTNER

6.5 HORSEPOWER

21" REAR-DISCHARGE LAWN MOWER

MODEL NUMBER P6553SDR (P6553SDRB)

964 77 14-02

ROTARY LAWN MOWER - - MODEL NUMBER P6553SDR (P6553SDRB) PRODUCT NUMBER 964 77 14-02

KEY NO.	PART NO.	DESCRIPTION	KEY NO.	PART NO.	DESCRIPTION
1	532 18 61-11	Upper Handle	29	532 08 83-48	Washer, Flat 3/8
2	532 15 36-05	Lower Handle	30	532 18 25-41	Axle Arm Assembly, RR
3	532 18 28-15	Control Bar	31	532 19 06-22	Selector Knob
4	532 18 27-55	Engine Zone Control Cable	32	532 18 25-37	Selector Spring
5	532 13 19-59	Handle Bolt	33	873 80 05-00	Nut 5/16-18
6	532 18 12-54	Handle Knob	34	532 18 25-42	Axle Arm Assembly, LR
7	532 05 17-93	Hairpin Cotter	35	532 18 55-73	Hubcap
8	532 06 64-26	Wire Tie	36	532 18 41-93	Bolt
9	532 18 04-79	Kit, Rear Door (Includes Key #16 and 17)	37	532 15 00-78	Thread Cutting Screw w/Sems 5/16-18 x 3/4
10	532 12 84-15	Pop Rivet	38	532 18 39-01	Washer
11	532 18 25-38	Support Bracket, LH	41	532 70 13-13	Spacer, Engine
12	532 18 25-39	Support Bracket, RH	42	532 05 39-98	Washer
13	817 06 04-10	Screw 1/4-20 x 5/8	43	532 18 70-38	Debris Shield
14	532 18 25-43	Handle Bracket Assembly, LH	44	532 19 04-03	Kit, Lawn Mower Housing (Includes Key Numbers 10, 11, 12 and 45)
15	532 18 25-45	Handle Bracket Assembly, RH	45	532 18 21-66	Danger Decal
16	532 18 00-71	Spring, LH	46	532 18 80-41	Blade Adapter
17	532 18 00-72	Spring, RH	47	532 17 50-52	Blade, 21"
18	532 13 20-04	Keps Locknut 1/4-20	48	532 85 10-74	Hardened Washer
19	532 17 95-85	Rope Guide	49	532 85 02-63	Helical Washer 3/8-24 x 1-3/8 Grade 8
20	532 17 92-05	Foot Guard, C.E.	50	532 17 96-17	Hex Head Machine Screw 3/8-24 x 1-3/8 Grade 8
21	532 05 45-83	Screw, Tapping 1/4-20 x 1/2	51	532 18 80-40	Screw
22	532 18 50-05	Engine Pulley	52	532 18 81-52	O-Ring
23	532 18 77-23	Key, Hi-Pro	89	532 12 51-62	Upstop Bracket
24	- - -	Engine, Briggs & Stratton, Model Number 125K02 (order parts from engine manufacturer)	90	532 75 06-34	Screw
25	532 85 09-99	Hex Head Thread Rolling Screw 3/8-16 x 1-1/8	- -	532 19 04-04	Operator's Manual, European
26	532 08 39-23	Hex Flange Nut	- -	532 19 04-06	Operator's Manual, Scandinavian
27	532 18 55-72	Wheel			
28	532 16 08-28	Shoulder Bolt 5/16-18 x .33			

NOTE: All component dimensions given in U.S. inches.
1 inch = 25.4 mm

ROTARY LAWN MOWER -- MODEL NUMBER P6553SDR (P6553SDRB) PRODUCT NUMBER 964 77 14-02

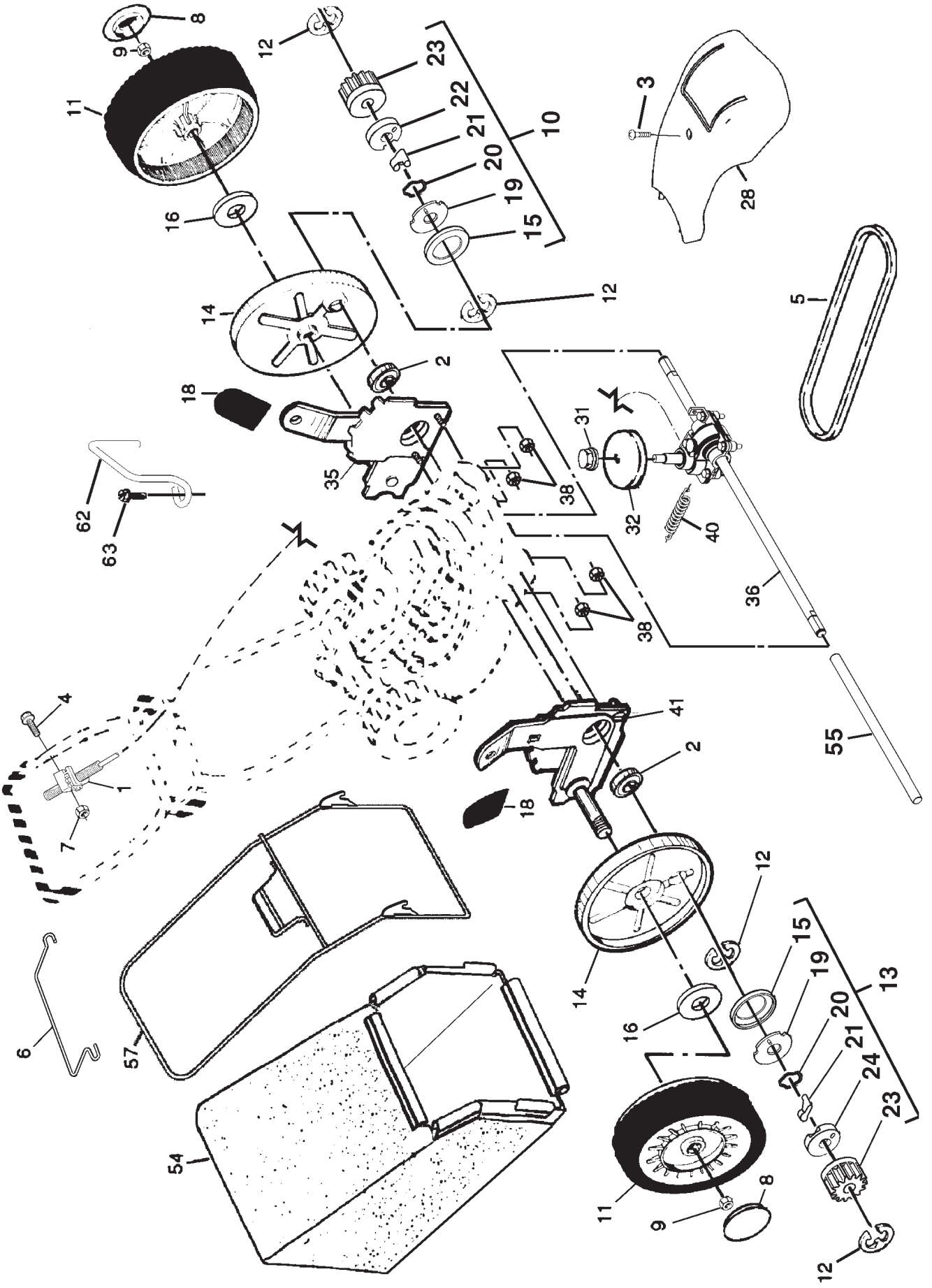

ROTARY LAWN MOWER - - MODEL NUMBER P6553SDR (P6553SDRB) PRODUCT NUMBER 964 77 14-02

KEY NO.	PART NO.	DESCRIPTION	KEY NO.	PART NO.	DESCRIPTION
1	532 18 91-82	Drive Control Assembly, with Cable	23	532 17 51-03	Gear, Pinion
2	532 16 99-11	Bearing, Wheel Adjuster	24	532 17 51-02	Retainer, Drive, RH
3	532 17 52-62	Pan Head Tapping Screw #10-24 x 2-3/4	28	532 18 14-68	Drive Cover
4	532 18 56-81	Hex Washer Head Screw 1/4-20 x 2.12	31	532 13 20-10	Hex Flange Nut
5	532 16 97-78	V-Belt	32	532 18 94-06	Drive Pulley
7	532 75 11-52	Locknut #10-24	35	532 18 09-15	Kit, Wheel Adjuster, LH
8	532 18 06-26	Hubcap			(Includes Knob and Bearing)
9	532 14 52-12	Locknut	36	532 18 72-12	Gearcase Assembly (See Breakdown)
10	532 18 83-31	Pinion Assembly, LH	38	873 80 04-00	Locknut 1/4-20
11	532 18 07-67	Wheel & Tire Assembly	40	532 18 22-26	Spring
12	812 00 00-58	E-Ring	41	532 18 09-14	Kit, Wheel Adjuster, RH
13	532 18 83-30	Pinion Assembly, RH			(Includes Knob and Bearing)
14	532 18 94-03	Dust Cover	54	532 19 04-08	Grassbag Assembly
15	532 18 41-72	Seal, Friction	55	532 17 57-39	Driveshaft Cover
16	532 06 77-25	Washer 1/2 x 1-1/2 x .134	57	532 18 88-15	Frame, Grassbag
18	532 17 01-43	Selector Knob	62	532 18 38-65	Belt Keeper
19	532 17 51-04	Disk, Drive	63	532 17 37-15	Screw
20	532 18 82-91	Spring, Torsion			
21	532 17 50-98	Pawl			
22	532 17 51-05	Retainer, Drive, LH			

NOTE: All component dimensions given in U.S. inches.
1 inch = 25.4 mm

ROTARY LAWN MOWER - - MODEL NUMBER P6553SDR (P6553SDRB)
PRODUCT NUMBER 964 77 14-02
GEARCASE ASSEMBLY - PART NUMBER 532 18 72-12

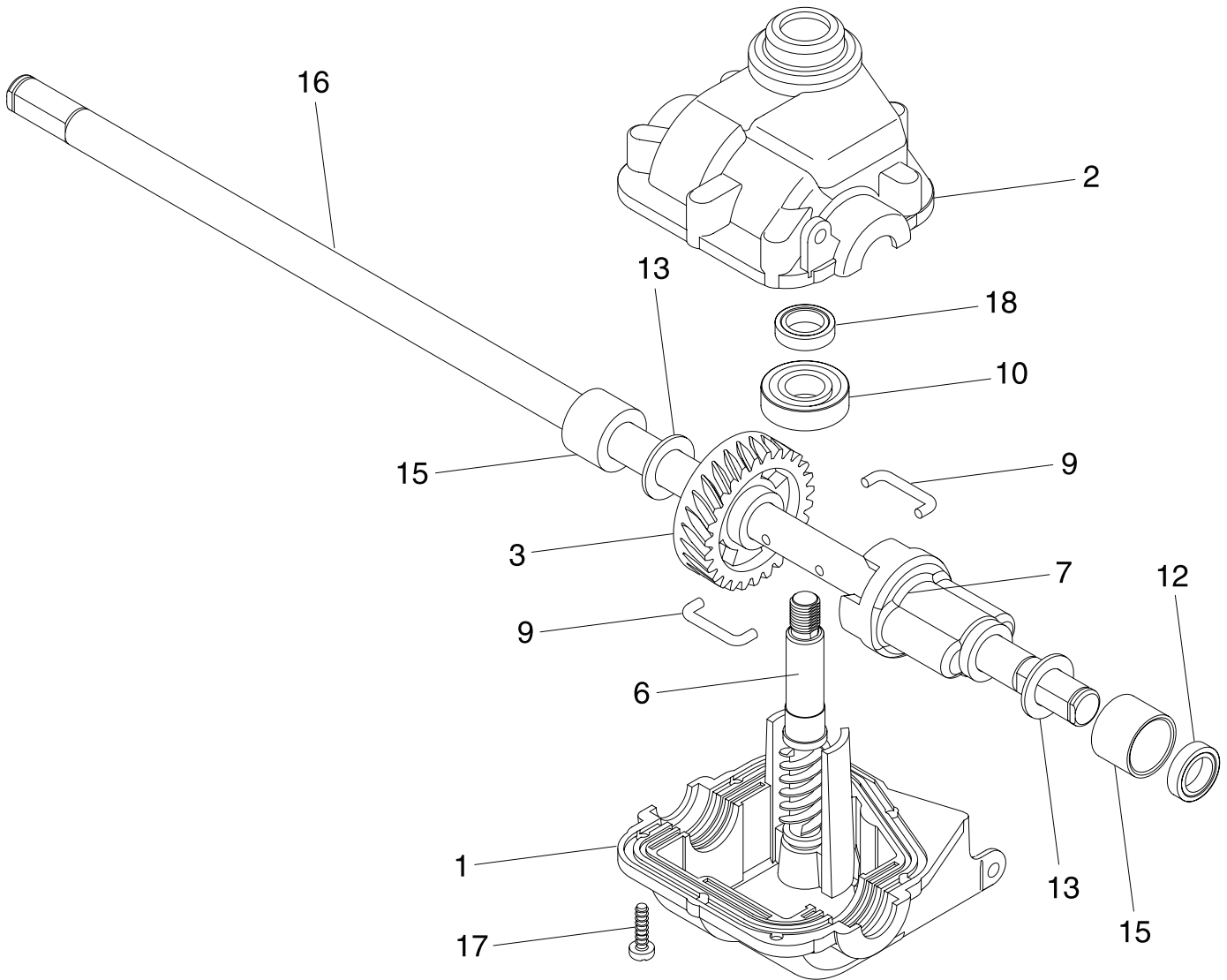

KEY NO.	PART NO.	DESCRIPTION
1	532 18 75-25	Case, Lower
2	532 18 75-26	Case, Upper
3	532 18 34-99	Gear, 27 Teeth
6	532 18 75-27	Shaft, Input
7	532 18 75-28	Spacer
9	532 18 35-05	Wire, Formed
10	532 18 35-06	Bearing, Ball
12	532 18 35-08	Seal, Output Shaft
13	532 18 35-09	Washer
15	532 18 35-11	Bushing
16	532 18 75-29	Shaft, Output
17	532 18 35-13	Screw
18	532 18 35-14	Seal, Input Shaft

NOTE: Use Dow Corning #709 to reseal Gear Case Halves.

NOTE: All component dimensions given in U.S. inches.
 1 inch = 25.4 mm